

# ELVRO 3000, HYDRO 501

건축물내 수직교통 생산성 향상의 솔루션



인천국제공항  
ELVRO 3000  
3,000kg/2,000kg/1,150kg



(주)농심 중국상해공장  
HYDRO 501  
3,000kg

산업현장 수직물류이동의 생산성 향상

최첨단성능과 고품질의 **송산 ELVRO 3000, HYDRO 501**과 함께 실현되고 있습니다.

**ELVRO 3000**

**고성능 로프식 엘리베이터(AC-VVVF INVERTOR DRIVE)**

방폭, 방진, 방습, 고하중, 초대형, 화물용, 인화물용, 승객용  
경사형 엘리베이터(Inclined Elevator)

**HYDRO 501**

**차세대 유압식 엘리베이터(ELECTRO-HYDRAULIC)**

고속, 고하중, 특수용도, 화물용, 인화물용, 승객용, 직·간접식

**AUTO LIFT**

**산업용 전자동 물류 시스템(Industrial Auto-Transportation System)**

SONGSAN의 산업용 엘리베이터는 최고의 품질과 완벽한 성능으로 국내외 산업현장의 수직물류이동 성력화를 선도해 오고 있습니다.

기존 화물용 승강기에서 크게 결여되어온 안전성, 신뢰성, 내구성, 편의성을 세계 수준으로 격상시킨 AC-VVVF 인버터 기종 ELVRO 3000과 차세대 유압식 기종 HYDRO 501은 **초소형에서 20톤이상 초대형 용량까지** 다양한 규격과 운행 환경에 따라 **방폭, 방진, 방습 등 특수형 및 기본형으로 제작·설치**됩니다.

특수승강설비 TOP MAKER인 SONGSAN은 최고 수준의 특수 엘리베이터 전문 KNOW-HOW와 첨단 테크놀로지를 바탕으로 표준규격형 엘리베이터에 고객의 필요에 따른 다양한 부가사양을 적용하여 드립니다. SONGSAN은 고객의 안전과 편의를 최우선으로 하는 완벽하고 철저한 사후관리로 최고의 명성과 신화를 구축해오고 있습니다.



상동 홈플러스  
ELVRO 3000  
1,600kg/24인승



BASF(독) 울산  
ELVRO 3000, 방폭형  
10톤



주안역사  
HYDRO 501  
1,000kg/15인승



DMZ 제3땅굴  
INCLINED SHUTTLE T48  
48인승/350m  
**세계최대규격**



## ELVRO 3000

### 방폭형 화물용 엘리베이터

Explosion-proof lifts for the chemical and petro-chemical industries

적재하중 20ton 이상의 고하중용 엘리베이터를 비롯하여 먼지가 많은 곳에서 사용 가능한 방진형, 습기가 많은 곳에서 필요한 방습형, 폭발 위험이 있는 화학공장에서 필요한 방폭형 등 산업용 특수엘리베이터 ELVRO 3000



### 적재하중 검출 모니터링 장치

엘리베이터 적재하중 실시간 검출 모니터링은 (주)송산만의 특허(제10-0621457호)등록된 기술이므로 무단도용 및 복제시 특허법에 의한 법적 처벌과 배상책임이 있습니다.

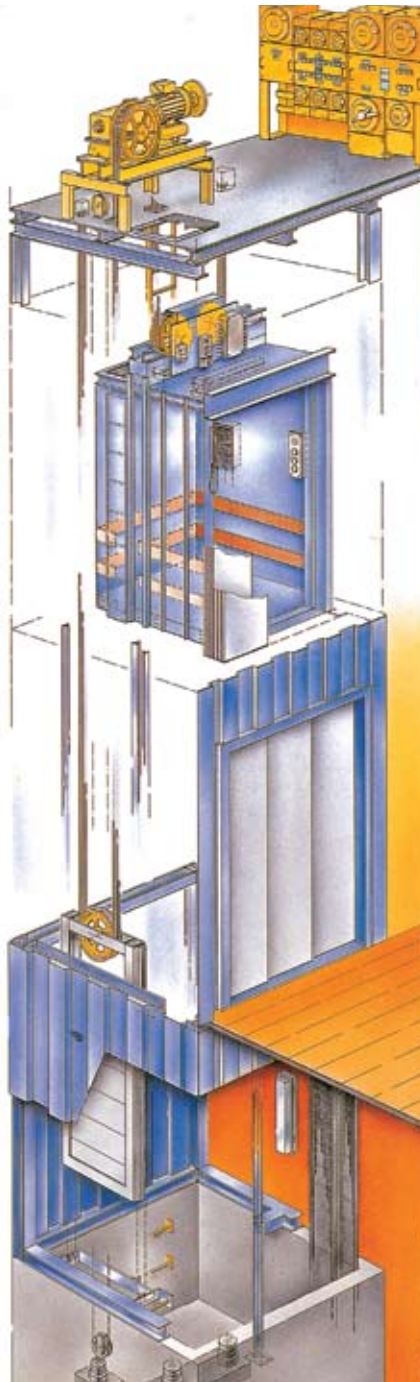

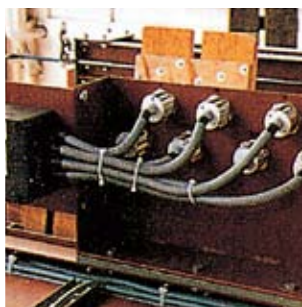

- Explosion-proof
- Heavy Duty Special Button(방폭·내충격 특수운전조작반)



인천국제공항



## ELVRO 3000

로프식 화물용 엘리베이터  
Freight Elevator ELVRO 3000

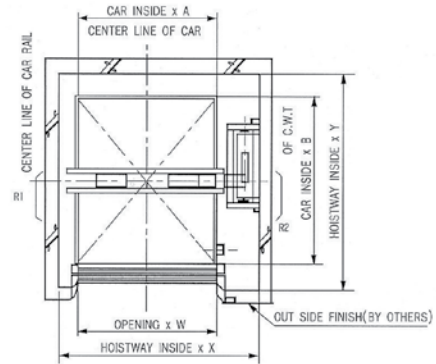
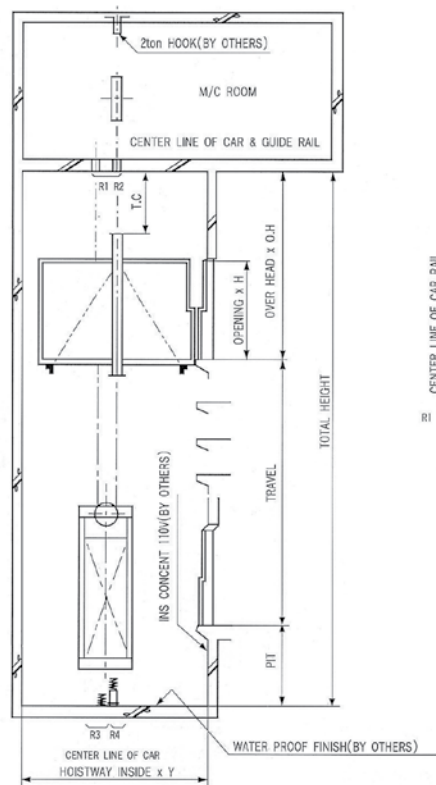

PLAN OF HOISTWAY

### AC-VVVF INVERTOR VECTOR DRIVE SYSTEM

Model No	Capacity (kg)	Speed (M/min)	Car Inside		Opening		Hoistway Inside		M/C Room Size			O,H	PIT	Reaction Force				Power (W)
			W	D	W	H	X	Y	Width	Depth	Height			R1	R2	R3	R4	
GF207632US	750	30 (60)	1600	1800	1600	1800	2500	2350	2500	3000	2100	3750	1300	5500	6000	6400	7500	5.5
GF210032US	1000		1700	2000	1700	2100	2600	2550						6100	7200	8600	9000	5.5
GF215032US	1500		1800	2400	1800	2100	2700	2950	3000	3500	2100	4200	1500	8400	9600	10200	12200	9
GF220032US	2000		2000	2800	2000	2100	2900	3350						9000	13500	12600	15500	13
GF225032US	2500		2400	3000	2400	2400	3300	3550	3000	5000	2100	4800	1500	10800	16400	15700	19500	15
GF230032US	3000		2800	3400	2800	2500	3700	3950						12800	19600	18600	23100	19
GF240032US	4000		3000	4500	3000	2500	4150	5050	3500	6000	2100	5200	1800	17000	26100	24800	30800	22
GF250032US	5000		3200	5000	3200	3000	4350	5550						21300	32600	31000	38500	29
HF80022US	8000		3500	5500	3500	3200	4700	6100	3500	6000	2100	6000	2000	1600	9800	23400	48900	37
HF10722US	10000		4000	6000	4000	3500	5200	6600						1850	11500	26000	52000	45

※Minimum Floor Height : MFH=1.5H+600



## HYDRO 501

유압식 화물용 엘리베이터  
Hydraulic Freight Elevator

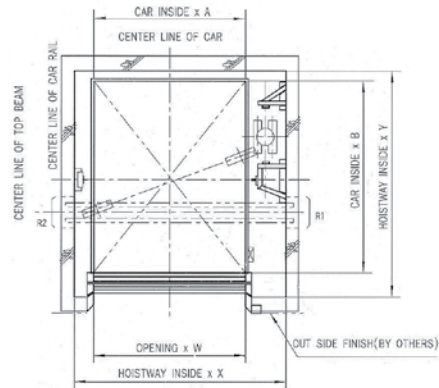
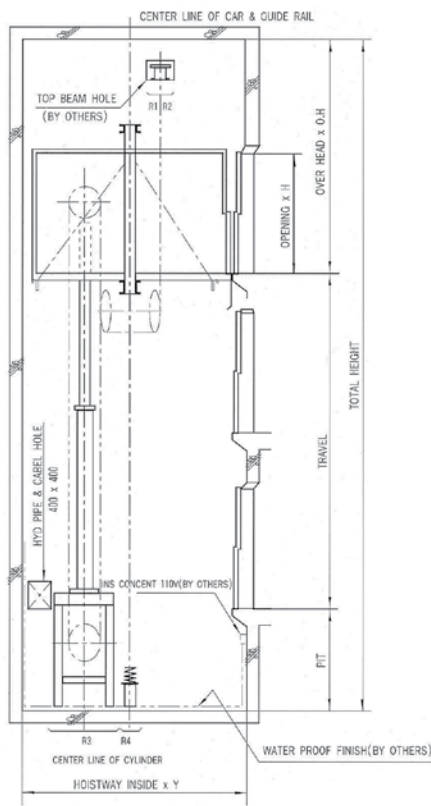

PLAN OF HOISTWAY

### Hydraulic

Model No	Capacity (kg)	Speed (M/min)	Car Inside		Opening		Hoistway Inside		M/C Room Size			O,H	PIT	Reaction Force				Power (kW)
			W	D	W	H	X	Y	Width	Depth	Height			R1	R2	R3	R4	
HF07522US	750	20 (30)	1600	1800	1600	1800	2500	2350	2500	3000	2100	4100	1300	1000	1500	6500	12500	11
HF10022US	1000		1700	2000	1700	2100	2600	2550						1150	1800	6900	14500	14
HF15022US	1500		1800	2400	1800	2100	2700	2950	3000	3500	2100	4400	1500	300	3900	8000	20600	16
HF20022US	2000		2000	2800	2000	2900	3350	400						4800	8900	25400	19	
HF25022US	2500		2400	3000	2400	2500	3300	3550	3000	5000	2100	4700	1500	400	5400	9700	28800	26
HF30022US	3000		2800	3400	2800	2500	3700	3950						400	5900	10500	31500	29
HF40022US	4000		3000	4500	3000	2500	4150	5050	3500	5500	2100	4800	1500	1020	7180	16400	35900	39
HF50022US	5000		3200	5000	3200	3000	4350	5550						1450	8750	20400	43750	47
HF80022US	8000		4000	6000	4000	3200	5200	6500	3500	6000	2100	5500	1800	1600	9800	23400	48900	65
HF10722US	10000		4500	8000	4500	3500	5700	8700						1850	11500	26000	52000	75

※Minimum Floor Height : MFH=1,5H+600



## HYDRO 501

유압식 승객용 엘리베이터  
Hydraulic Passenger Elevator

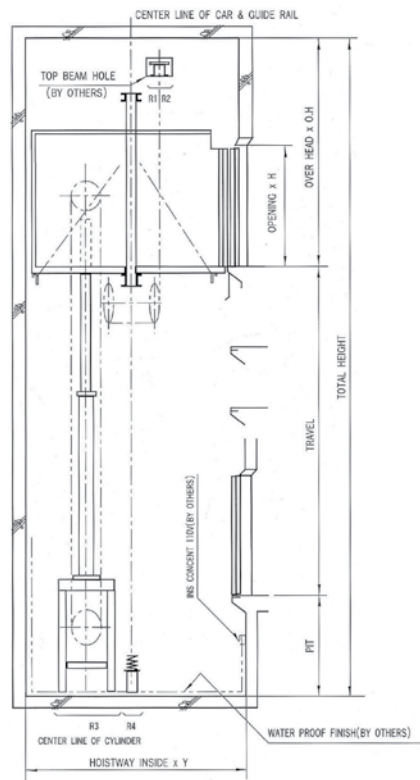

SECTION OF HOISTWAY

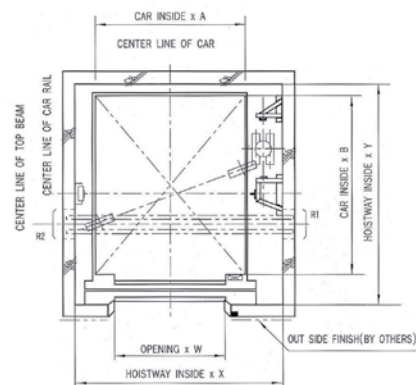

2 PANEL CENTER OPEN

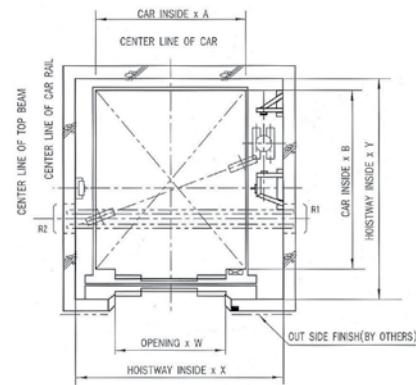

4 PANEL CENTER OPEN

### 2 Panel Center Open

Model No	Capacity (kg)	Speed (M/min)	Car Inside		Opening		Hoistway Inside		M/C Room Size			O.H	PIT	Reaction Force				Power (kW)
			W	D	W	H	X	Y	Width	Depth	Height			R1	R2	R3	R4	
HP7502C	750	30 (45)	1400	1350	900	2100	2300	2000	2500	3000	2100	4400	1300	1000	1500	6500	12500	11
HP1002C	1000		1600	1500	1000		2500	2150						1150	1800	6900	14500	12
HP1352C	1350		1800	1700	1000		2700	2350						1250	2200	8000	20600	15

### 4 Panel Center Open

Model No	Capacity (kg)	Speed (M/min)	Car Inside		Opening		Hoistway Inside		M/C Room Size			O.H	PIT	Reaction Force				Power (kW)
			W	D	W	H	X	Y	Width	Depth	Height			R1	R2	R3	R4	
HS15024CS	1500	20 (30)	2200	2400	1600	2100	3150	3000	3000	3500	2100	4600	1500	300	3900	8000	20600	16
HS20024CS	2000		2400	2600	1800		3400	3200						500	4800	8900	25400	19
HS25024CS	2500		2600	3000	2000		3650	3600						500	5400	9700	28800	26
HS30024CS	3000		2600	3000	2400		3650	3600						500	5900	10500	31500	29



# HYDR 501

덤 웨이터  
CHAM-201

## Table Type

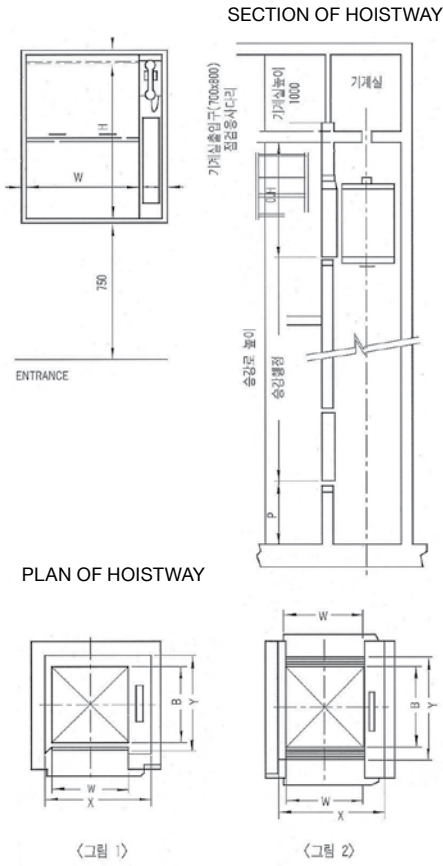

## Floor Type

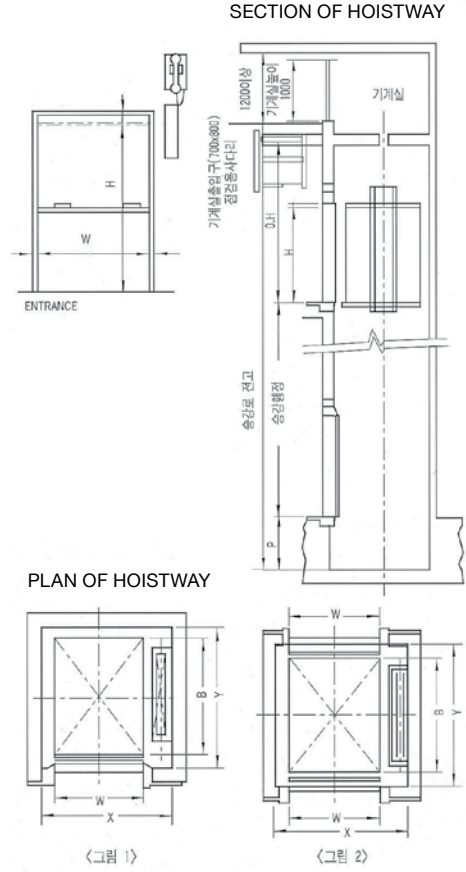

## 종류 및 표준치수

No.	Model No	적용 도면	Capacity (kg)	Speed (M/min)	Door Type		Opening A×H (너비×높이)	Car B (깊이)	X (너비)	Hoistway		OH(Over Head)		P (PIT 깊이)
					Door	Car Door				Car Door 무	Car Door 유	Car Door 무	Car Door 유	
1	ST-50S-20	1	50	20 (30)	2매 Door 상하개폐	2매 Door 상하개폐	550×700	550	980	700	740	1285	1475	750
2	ST-50D-20	2								780				
3	ST-75S-20	1	600×800				600	1030	750	790	1360	1550		
4	ST-50D-20	2							830					
5	ST-100S-20	1	100				700×900	700	1130	850	890	1510	1700	
6	ST-100D-20	2								930				
7	ST-150S-20	1	150				800×1000	800	1230	950	990	1660	1850	
8	ST-150D-20	2								1030				
9	SL-200S-30	1	200	30 (45)	2매 Door 상하개폐 또는 1매 Door 상개폐	안전봉 또는 1매 Door 상개폐	800×1200	1000	1260	1190	1230	최상층 출입구가 1매 Door일때 : 2560	최상층 출입구가 2매 Door일때 : 2250	최상층 출입구가 1매 Door일때: 300 최상층 출입구가 2매 Door일때: 600
10	SL-200D-30	2								1340				
11	SL-300S-30	1	300				850×1200	1150	1310	1380	1380			
12	SL-300D-30	2								1380				

# HYDRO 501

자동차용 엘리베이터  
Car Lift HYDRO 501

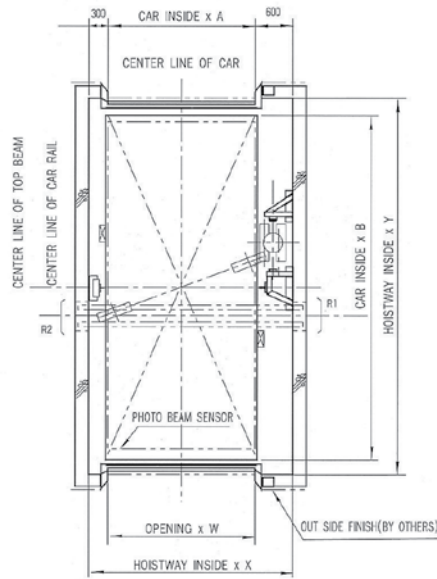
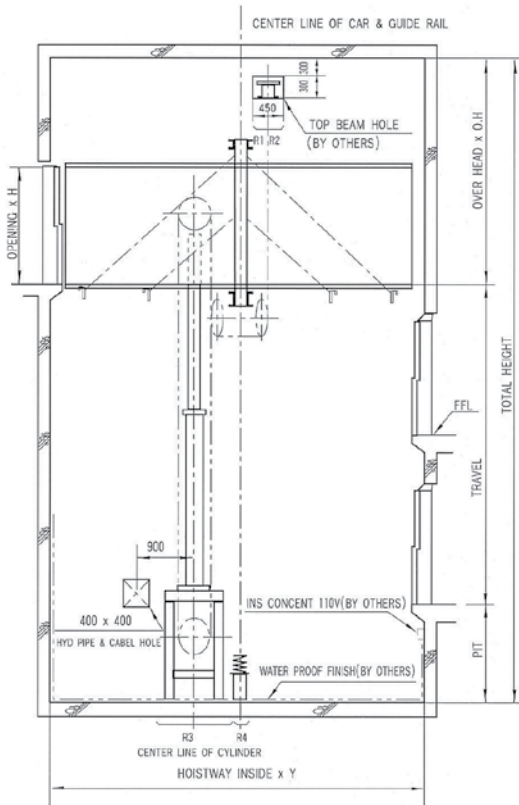

PLAN OF HOISTWAY

34  
35

## Single Direction Entrance Type

Model No	Capacity (kg)	Speed (M/min)	Car Inside	Opening	Hoistway Inside	O.H	PIT	Reaction Force				Power (kW)
			AxB	WxH	XxY			R1	R2	R3	R4	
HC20022US1	2000	20 (30)	2250×5200	2250×1800	3150×5600	4100	1250	400	4800	8900	25400	19
HC20022US2	2000		2350×5400	2350×1800	3250×5800	4100	1250	400	4800	8900	25400	19
HC20022US3	2500		2500×6000	2500×1800	3400×6400	4100	1250	430	5100	9300	26500	26
HC20022US4	2500		2600×6200	2600×2100	3500×6600	4100	1250	430	5100	9300	26500	26

※MFH=1.5H+600

## Through Direction Entrance Type

Model No	Capacity (kg)	Speed (M/min)	Car Inside	Opening	Hoistway Inside	O.H	PIT	Reaction Force				Power (kW)
			AxB	WxH	XxY			R1	R2	R3	R4	
HC20022UT1	2000	20 (30)	2250×5200	2250×1800	3150×5700	4100	1250	400	4800	8900	25400	19
HC20022UT2	2000		2350×5400	2350×1800	3250×5900	4100	1250	400	4800	8900	25400	19
HC20022UT3	2500		2500×6000	2500×1800	3400×6500	4100	1250	430	5100	9300	26500	26
HC20022UT4	2500		2600×6200	2600×2100	3500×6700	4100	1250	430	5100	9300	26500	26

※MFH=1.5H+600 M/C Room Size=3200×3000